



Designation: D5179 – 16 (Reapproved 2021)

# Standard Test Method for Measuring Adhesion of Organic Coatings in the Laboratory by Direct Tensile Method<sup>1</sup>

This standard is issued under the fixed designation D5179; the number immediately following the designation indicates the year of original adoption or, in the case of revision, the year of last revision. A number in parentheses indicates the year of last reapproval. A superscript epsilon ( $\epsilon$ ) indicates an editorial change since the last revision or reapproval.

## 1. Scope

1.1 This test method covers the laboratory determination of organic coating adhesion to plastic substrates by mounting and removing a metal stud from the surface of the coating and measuring the force required to break the coating/substrate bond with a tensile tester. This test method may also be applied to substrates other than plastic.

1.2 This test method requires that the metal stud be adhered directly to the surface of a coated, cured panel (Fig. 1).

1.3 This test method is used to compare the adhesion of coatings to plastic or other substrates, thus allowing for a quantitative comparison of various coating/substrate combinations in laboratory conditions.

1.4 Other tensile test methods are Test Methods D4541, D7234, D7522, and ISO 4624 (but are not technically equivalent).

1.5 The values stated in SI units are to be regarded as standard. The values given in parentheses are mathematical conversions to inch-pound units that are provided for information only and are not considered standard.

1.6 *This standard does not purport to address all of the safety concerns, if any, associated with its use. It is the responsibility of the user of this standard to establish appropriate safety, health, and environmental practices and determine the applicability of regulatory limitations prior to use.*

1.7 *This international standard was developed in accordance with internationally recognized principles on standardization established in the Decision on Principles for the Development of International Standards, Guides and Recommendations issued by the World Trade Organization Technical Barriers to Trade (TBT) Committee.*

<sup>1</sup> This test method is under the jurisdiction of ASTM Committee D01 on Paint and Related Coatings, Materials, and Applications and is the direct responsibility of Subcommittee D01.23 on Physical Properties of Applied Paint Films.

Current edition approved Nov. 1, 2021. Published November 2021. Originally approved in 1991. Last previous edition approved in 2016 as D5179 – 16. DOI: 10.1520/D5179-16R21.

## 2. Referenced Documents

### 2.1 ASTM Standards:<sup>2</sup>

D4541 Test Method for Pull-Off Strength of Coatings Using Portable Adhesion Testers

D7234 Test Method for Pull-Off Adhesion Strength of Coatings on Concrete Using Portable Pull-Off Adhesion Testers

D7522 Test Method for Pull-Off Strength for FRP Laminate Systems Bonded to Concrete or Masonry Substrates

### 2.2 Other Standard:

ISO 4624 Paints and Varnishes—Pull-off test for adhesion<sup>3</sup>

## 3. Summary of Test Method

3.1 A metal stud is bonded directly to a coated cured panel. The adhesive is allowed to cure according to manufacturer's recommendations. The specimen is then subjected to test on a tensile tester equipped with an upper coupling adapter (Fig. 2), and a restraining device (Fig. 3).

3.2 If a coating is to fulfill its function of protecting or decorating a substrate, it must adhere to it for the expected service life. Because the substrate and its surface preparation (or lack of it) has a drastic effect on the adhesion of coatings, a method of evaluating the adhesion of a coating to different substrates or surface treatments, or of different coatings to the same substrate and treatment, is of considerable usefulness in the industry.

## 4. Significance and Use

4.1 The pull-off strength (commonly referred to as adhesion) of a coating is an important performance property that has been used in specifications. This test method serves as a means for uniformly preparing and testing organic coatings on plastic or other substrates.<sup>4</sup> Further information may be found in Appendix X1.

<sup>2</sup> For referenced ASTM standards, visit the ASTM website, www.astm.org, or contact ASTM Customer Service at service@astm.org. For *Annual Book of ASTM Standards* volume information, refer to the standard's Document Summary page on the ASTM website.

<sup>3</sup> Available from American National Standards Institute (ANSI), 25 W. 43rd St., 4th Floor, New York, NY 10036, http://www.ansi.org.

<sup>4</sup> Gray, K. N., Buckley, S. E., and Nelson, G. L., "Accessing Measurement Standards for Coating Adhesion to Plastics," *Modern Paint and Coatings Journal*, Vol 75, No. 10, October 1985, p. 160.

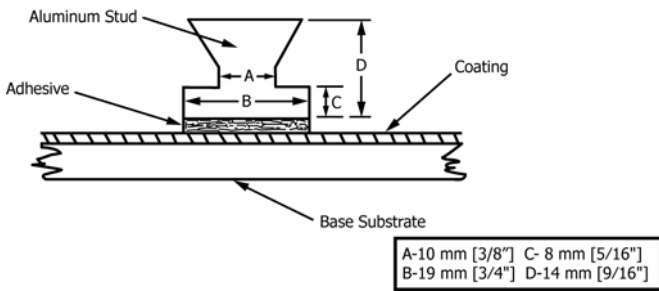

FIG. 1 Direct Tensile Model

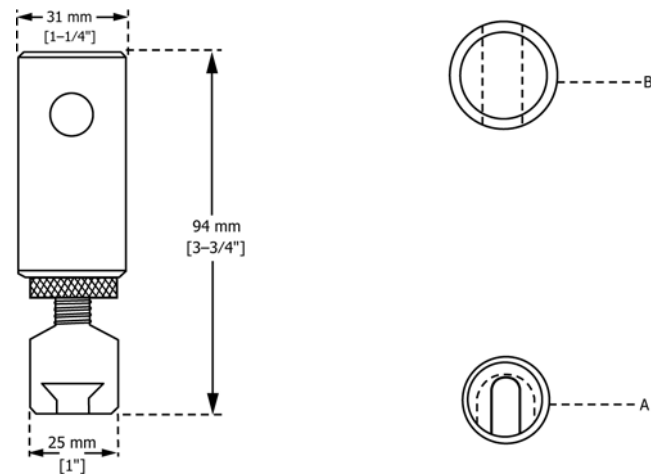

FIG. 2 Upper Coupling Adaptor

## 5. Apparatus and Materials

5.1 *Tensile Tester*—A properly calibrated testing machine that can be operated at constant rates of crosshead motion, and in which the error in the load measuring system shall not exceed  $\pm 1\%$  of the maximum load expected to be measured.

NOTE 1—A computer-controlled machine is preferable.

5.2 *Metal Stud*—The shape and dimensions of the stud are shown in Fig. 1. If aluminum studs are used, the surface for bonding may require treatment to improve adhesion. Such aluminum treatments are commercially available.

5.3 *Upper Coupling Adaptor*—The apparatus is shown in Fig. 2. The adaptor is 94 mm [3 3/4 in.] long, 31 mm [1 1/4 in.] in diameter at the top, and 25 mm [1 in.] in diameter at the bottom. The hole, indicated by “B,” is used to attach the adaptor to the tensile tester load cell. The hole has a 13-mm [1/2-in.] diameter. The machined opening indicated by “A,” is to receive the head of the metal stud.

5.4 *Restraining Device*—The apparatus is shown in Fig. 3A and 3B. The 13-mm [1/2-in.] diameter hole, marked “A,” in the 63.5-mm [2 1/2-in.] long, 31-mm. [1 1/4-in] diameter lower coupling adapter, is used to mount the device in the tensile tester. The top portion is 100 mm [4 in.] in diameter, 19 mm [3/4 in.] high, and is fitted with a hole slightly larger than 19 mm [3/4 in.] in diameter to allow stud clearance. The bottom screw portion is machined to fit with the top portion and is 13 mm [1/2 in.] thick. Fig. 3C illustrates the final appearance of the test assembly before it is tested.

5.5 *Wooden Applicators, or Cotton Swabs* or other means to clean excess adhesive from around the metal stud.

5.6 *Adhesive*, a suitable glue.<sup>5</sup>

5.7 *Bonding Weight*, a weight found suitable for consistently establishing the desired adhesive bond line for the chosen adhesive during samples preparation.

## 6. Preparation and Conditioning of Specimen

6.1 *Sanding Procedure*—Sand the large face of the stud with appropriate sandpaper, making certain that the surface is uniformly roughened. When sanding studs, sand straight up and down; rotate stud one quarter of a turn and continue sanding. Make certain the surface of the stud is flat but rough. While sanding, keep the stud face parallel to the sandpaper. Nonplanar surfaces cannot be used in testing because they lead to nonuniform bonding of the stud to the coated surface. Only flat (planar) studs should be used in testing. Planarity may be assessed by placing a stud on a flat surface and checking to see if the stud wobbles. Careful preparation of studs is essential for good adhesive adhesion.

6.2 *Cleaning Procedure*—Use a cleaning and surface treatment method known to be effective for metal studs. Commercial cleansers and metal surface treatments are available in form of liquids or ready-to-use wipes for many commonly used metals, including aluminum. Avoid touching the face of studs after cleaning.

6.3 Prepare the adhesive in accordance with the adhesive manufacturer’s recommendations. Apply the adhesive to the metal stud or the surface to be tested, or both, using a method recommended by the adhesive manufacturer. After assuring that the adhesive application surface is completely covered, press the metal stud onto the coated test substrate. Place the appropriate bonding weight on the stud to ensure good contact between the stud, adhesive, and surface of the coating. Clean the excess adhesive from the edge of the stud. Carefully remove the weight after allowing sufficient time for the adhesive to set.

NOTE 2—Substrate panels may be cut to any size that fits the restraining device in a manner that prevents the substrate from flexing. Be aware that as the area of the sample increases, the placement of the stub may become more critical in fitting the sample in the device.

NOTE 3—When the stud is pressed, excess adhesive should escape from under the stud. Excess adhesive buildup at the edge of the stud is a major source of error if allowed to cure. This excess must be removed from around the stud. The adhesive may be removed using a wooden applicator, cotton swabs, or another suitable method.

6.4 Based on the adhesive manufacturer’s recommendations and the anticipated environmental conditions, allow enough time for the adhesive to cure (see Note 4).

NOTE 4—A curing time of 2 h at room temperature using Elmer’s,

<sup>5</sup> Fast-curing adhesives may be used if they provide adequate adhesion between the metal stud and the coating being tested as long as they remain neutral to the coating. Cyanoacrylate or epoxy adhesives were found to be suitable for some coatings. From other work, it is noted, that some adhesives may penetrate certain coatings and soften the coating or the plastic substrate. Care in observation of unusual results is necessary to ensure against the possibility of error. The error may be suspected if an adhesive gives an unexpectedly low result. Adhesives that yield a brittle adhesive layer should not be used.

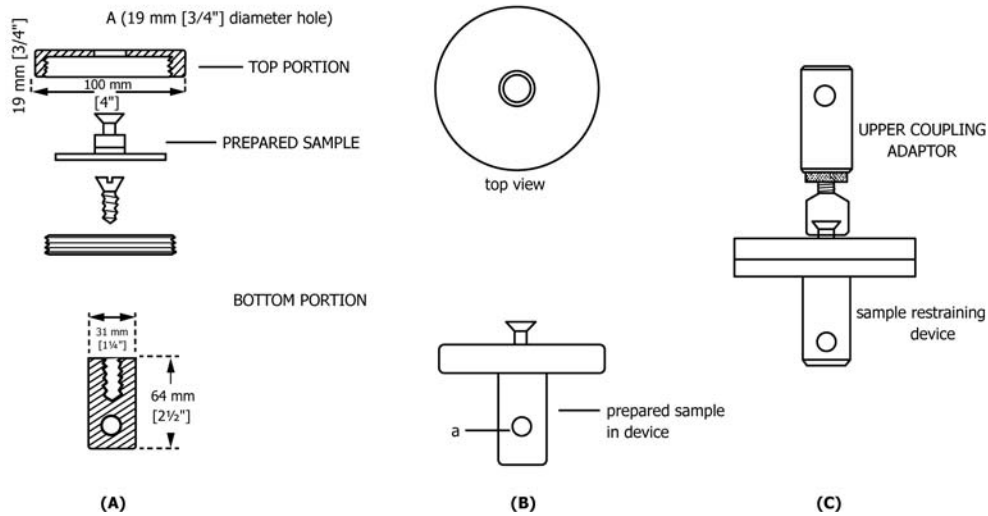

FIG. 3 Direct Tensile Restraining Device

Wonder Bond Plus, Super Glue<sup>6</sup> led to the results reported in the Precision and Bias Section.

NOTE 5—Studs should be cleaned from the remains of coating and adhesive, and the bonding surface prepared as described in 6.1 and 6.2. Seek adhesive manufacturer advice if removal of the adhesive becomes difficult.

6.5 *Conditioning*—Condition the coated substrates and test in the same environment or immediately on removal therefrom, as specified by manufacturer’s recommendations or agreed upon by the purchaser and the seller.

6.6 *Scoring*—Scored samples constitute a different test, and this procedure should be clearly reported with the results. If scoring around the test surface adhered to the metal stud is employed, extreme care is required to prevent micro-cracking in the coating, since such cracks may cause reduced adhesion values. Scoring is only recommended for thicker film coatings, that is, thicknesses greater than 500 μm [20 mil].

## 7. Procedure

7.1 Install the restraining device and upper adaptor into a calibrated tensile tester.

7.2 Verify that the crosshead speed is set at 1 mm/min [0.04 in./min] or such that the test is completed in about 100 s or less.

7.3 Place the specimen to be tested in the restraining device (Fig. 3A and 3B). Pre-position the crosshead and then slowly lower it so the upper coupling adaptor can be attached to the test specimen. Take care to prevent the crosshead from impacting into the top of the specimen. Carefully attach the upper coupling adaptor to the stud (Fig. 3C).

NOTE 6—Make sure that the substrate is not deformed during testing.

7.4 Start the tensile test. Stop the test when the stress returns to zero.

7.5 Examine the test area on each specimen to determine the type of coating failure, rating it according to the following:

- 7.5.1 Adhesive failure of the coating at the substrate, A,
- 7.5.2 Cohesive failure in the coating, C,
- 7.5.3 Combination of adhesive failure at the coating/substrate interface and cohesive failure in the coating, AC,
- 7.5.4 Adhesive failure at the stud, S, and
- 7.5.5 Combination of adhesive failure at the stud and cohesive failure in the coating, CS, with assessment of the percentage of adhesive and cohesive failure.

7.6 For multilayer coatings, note if the failure is between the layers. If so, label as *CM*.

7.7 Number and retain all test specimens for adhesion failure calculations. Test five specimens of each coated substrate. If one specimen differs significantly from the other four at the same time, fails because of an uneven (nonplanar) stud, or for any other reason performs unlike the other four, test a replacement specimen.

NOTE 7—Examine the stud and specimen carefully. Adhesive should have been applied uniformly to the entire stud surface. Coating should have pulled off uniformly over the entire stud surface either with adhesive failure from the substrate (A) or cohesive failure in the coating (C). If failure is less than 90 % A or C or (or CM), if the adhesive has failed at the stud, retest exercising particular care in the specimen and stud preparation.

NOTE 8—The percentage of adhesive failure at the coating/substrate interface is determined by inspecting the tested area on the substrate. This may be assessed by overlaying a transparent sheet grid marked in 2.54-mm [0.10-in.] squares and estimating the percentage of adhesive failure in each square that lies over the tested area. These percentages may then be averaged to obtain failure for each specimen.

## 8. Report

8.1 Report the following information:

8.1.1 Number of tests, the maximum stress obtained in each test, and the type of failure. Calculate and report mean and standard deviation for tensile strength for each coating/substrate combination tested

8.1.2 Conditioning of the specimens.

8.1.3 Temperature and relative humidity during the test period.

<sup>6</sup> Elmer’s glue is a registered trademark of Elmer’s Products, Inc.